



# OWNER'S MANUAL

INSTALLATION AND OPERATING INSTRUCTIONS  
REPAIR PARTS LIST

## “SSCX” AND “SSCXS” SERIES CENTRIFUGAL PUMP

High Head

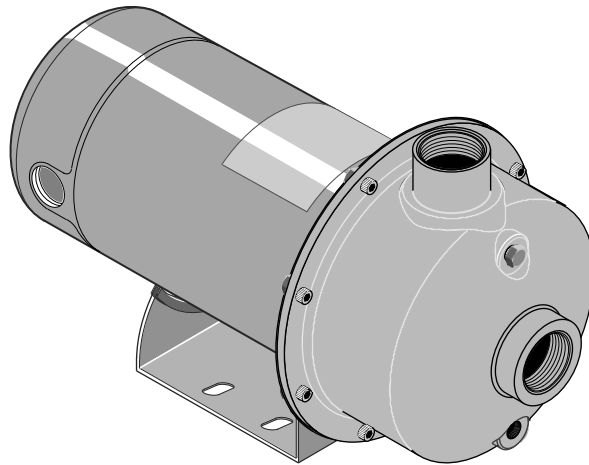

### MODELS

HP	Model Number	ODP MOTORS		TEFC MOTORS	
		115/230/60/1	208-230/460/60/3	115/230/60/1	208-230/460/60/3
1/2	SS1XN-1/2	B78635	B78636	B78647	B78648
3/4	SS1XN-3/4	B78637	B78638	B78649	B78650
3/4	SS1XS-3/4	B82411	B82412	B82413	B82414
1	SS1XN-1	B78639	B78640	B78651	B78652
1	SS1XS-1	B82415	B82416	B82417	B82418
1-1/2	SS1XN-1 1/2	B78641	B78642	B78653	B78654
1-1/2	SS1XS-1 1/2	B82419	B82420	B82421	B82422
2	SS1 1/4 XN-2	B78643*	B78644	B78655*	B78656
2	SS1XS-2	B82423*	B82424	B82425	B82426
2-1/2	SS1 1/4 XN-2 1/2	B78645*	B78646	B78657*	B78658
2-1/2	SS1XS-2 1/2	B82427*	B82428	B82429*	B82430

\* 230 Volt only.

Berkeley Pumps / 293 Wright Street / Delavan, WI 53115

# Recommended pump suction and discharge connections

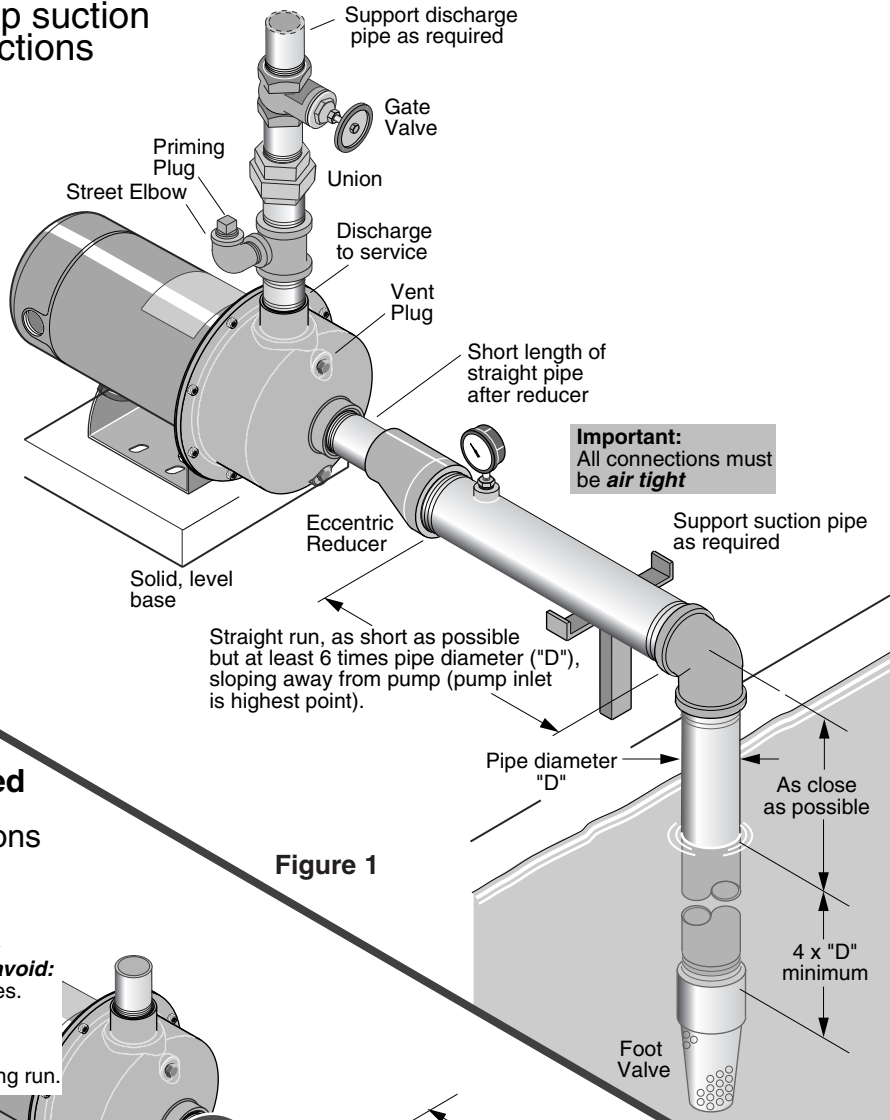

Figure 1

## Not recommended pump suction and discharge connections

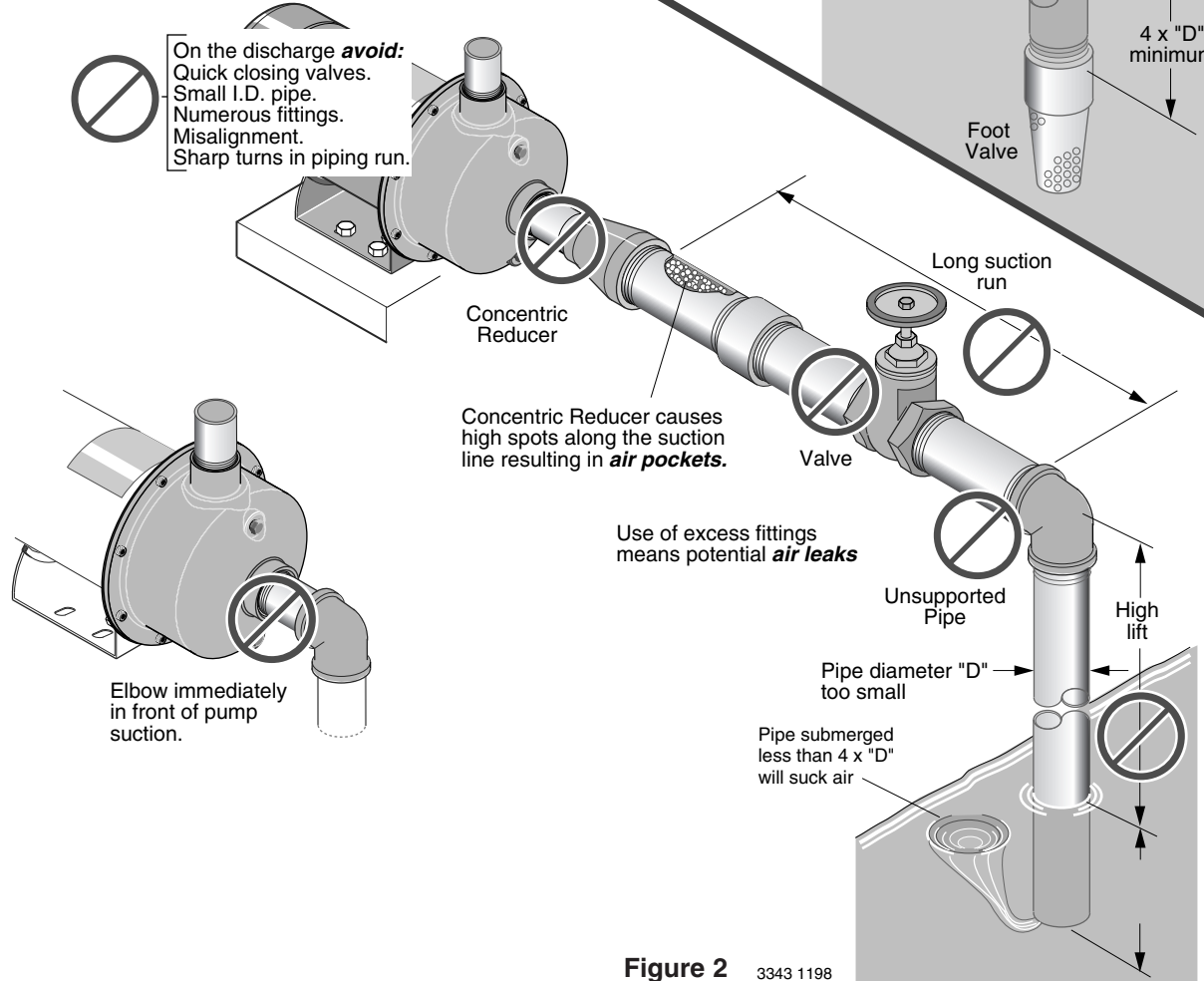

Figure 2 3343 1198

## PIPING - GENERAL

Support both suction and discharge piping independently at a point near the pump to avoid putting a strain on the pump housing. Start all piping **AT THE PUMP**.

Increase pipe diameter at both the suction and discharge by one (1) standard pipe size (minimum) to obtain desired performance and flow rate. Refer to Table I when sizing pipe for your pumping system.

**NOTE:** Do not use pipe with **smaller** diameter on the suction side of pump.

**TABLE I**

Pipe Tapping Size On Pump		Recommended Pipe Size	
Suction	Discharge	Suction	Discharge
1-1/4	1	1-1/2	1-1/4
1-1/2	1-1/4	2	1-1/2

## SUCTION PIPE

Increase pipe size from pump tapping as shown in Table I.

Figure 1 (Page 2) depicts a recommended run of pipe and fittings for the suction side of a centrifugal pump. Please refer to this illustration when choosing pipe and fittings for your suction connection.

**IMPORTANT:** All connections must be air tight!

Figure 2 (Page 2) depicts conditions that are **NOT DESIRABLE** on the suction side of a centrifugal pump and may cause problems in flow rate and priming. Please look this illustration over carefully before choosing pipe and fittings for your suction connection.

## DISCHARGE PIPING

Increase pipe size from pump tapping as show in Table I. Figure 1 (Page 2) depicts a recommended run of pipe and fittings for the discharge. Install tee with priming plug as close to pump as possible. Figure 2 (Page 2) notes conditions that should be avoided. Please read over carefully before making discharge connection.

## PRIMING THE PUMP

A pump is primed when all air in the suction line and pump volute has been evacuated and replaced with water.

**To Prime:**

1. Close valve in discharge line.
2. Remove priming plug from tee and fill pump and suction line with water until water is flowing back out of tee.
3. Replace priming plug.
4. Start pump and slowly open valve until desired water flow is achieved.

**NOTE:** If no water is pumped after 5 minutes, turn off pump, close valve, and repeat steps 1 thru 4.

**▲ WARNING** **Risk of explosion and scalding.** Never run pump against closed discharge. To do so can boil water inside pump, causing hazardous pressure buildup and possible explosion.

**▲ CAUTION** **Risk of flooding.** Do not run the pump dry. This will damage mechanical seal and void warranty. It may cause burns to person handling pump.

**▲ CAUTION** **Motor normally operates at high temperature and will be too hot to touch.** It is protected from heat damage during operation by an automatic internal cutoff switch. Before handling pump or motor, stop motor and allow it to cool for 20 minutes.

**TABLE II - RECOMMENDED FUSING AND WIRING DATA - 60/50 CYCLE MOTORS**

MODEL	MOTOR HP	VOLTAGE	MAX. LOAD AMPERES	BRANCH FUSE* RATING AMPS	DISTANCE IN FEET FROM MOTOR TO METER				
					0' TO 100'	101' TO 200'	201' TO 300'	301' TO 400'	401' TO 500'
					WIRE SIZE				
<b>SINGLE PHASE - ODP MOTORS</b>									
SS1XN-½	1/2	115/230/1	9.9/4.95	15/15	14/14	10/14	10/14	6/14	6/12
SS1XN-¾	¾	115/230/1	12.4/6.2	20/15	12/14	10/14	8/14	6/12	6/12
SS1XS-¾	¾	115/230/1	14.8/7.4	20/15	12/14	8/14	6/14	6/12	4/10
SS1XN-1	1	115/230/1	14.8/7.4	20/15	12/14	8/14	6/14	6/12	4/10
SS1XS-1	1	115/230/1	19.9/9.95	25/15	10/14	8/14	6/12	4/10	4/10
SS1XN-1½	1-1/2	115/230/1	19.9/9.95	25/15	10/14	8/14	6/12	4/10	4/10
SS1XS-1½	1-1/2	115/230/1	24.0/12.0	30/15	10/14	6/12	6/12	4/10	3/8
SS1½XN-2	2	115/230/1	24.0/12.0	30/15	10/14	6/12	6/12	4/10	3/8
SS1XS-2	2	115/230/1	26.0/13.0	35/20	8/12	6/12	4/10	4/10	3/8
SS1½XN-2½	2-1/2	115/230/1	26.0/13.0	35/20	8/12	6/12	4/10	4/10	3/8
SS1XS-2½	2-1/2	115/230/1	26.0/13.0	35/20	8/12	6/12	4/10	4/10	3/8
<b>SINGLE PHASE - TEFC MOTORS</b>									
SS1XN-½	1/2	115/230/1	8.2/4.1	15/15	14/14	12/14	10/14	8/14	8/12
SS1XN-¾	¾	115/230/1	11.6/5.8	20/15	14/14	10/14	8/14	6/14	6/12
SS1XS-¾	¾	115/230/1	13.2/6.6	20/15	12/14	10/14	8/14	6/12	6/12
SS1XN-1	1	115/230/1	13.2/6.6	20/15	12/14	10/14	8/14	6/12	6/12
SS1XS-1	1	230/1	6.9	15	14	14	14	12	12
SS1XN-1½	1-1/2	230/1	6.9	15	14	14	14	12	12
SS1XS-1½	1-1/2	230/1	8.7	15	14	14	12	12	10
SS1½XN-2	2	230/1	8.7	15	14	14	12	12	10
SS1XS-2	2	230/1	9.8	15	14	14	12	10	10
SS1½XN-2½	2-1/2	230/1	9.8	15	14	14	12	10	10
SS1XS-2½	2-1/2	230/1	9.8	15	14	14	12	10	10
<b>THREE PHASE - ODP MOTORS</b>									
SS1XN-½	1/2	230/460/3	2.3/1.15	15	14/14	14/14	14/14	14/14	14/14
SS1XN-¾	¾	230/460/3	3.1/1.55	15	14/14	14/14	14/14	14/14	14/14
SS1XS-¾	¾	230/460/3	3.6/1.8	15	14/14	14/14	14/14	14/14	14/14
SS1XN-1	1	230/460/3	3.6/1.8	15	14/14	14/14	14/14	14/14	14/14
SS1XS-1	1	230/460/3	4.7/2.35	15	14/14	14/14	14/14	14/14	14/14
SS1XN-1½	1-1/2	230/460/3	4.7/2.35	15	14/14	14/14	14/14	14/14	14/14
SS1XS-1½	1-1/2	230/460/3	6.8/2.4	15	14/14	14/14	14/14	12/14	12/14
SS1½XN-2	2	230/460/3	6.8/2.4	15	14/14	14/14	14/14	12/14	12/14
SS1XS-2	2	230/460/3	8.5/4.25	15	14/14	14/14	14/14	12/14	12/14
SS1½XN-2½	2-1/2	230/460/3	8.5/4.25	15	14/14	14/14	14/14	12/14	12/14
SS1XS-2½	2-1/2	230/460/3	8.5/4.25	15	14/14	14/14	14/14	12/14	12/14
<b>THREE PHASE - TEFC MOTORS</b>									
SS1XN-½	1/2	208-230/460/3	2.2/1.1	15	14/14	14/14	14/14	14/14	14/14
SS1XN-¾	¾	208-230/460/3	2.9/1.45	15	14/14	14/14	14/14	14/14	14/14
SS1XS-¾	¾	208-230/460/3	3.6/6.8	15	14/14	14/14	14/14	14/14	14/14
SS1XN-1	1	208-230/460/3	3.6/6.8	15	14/14	14/14	14/14	14/14	14/14
SS1XS-1	1	208-230/460/3	4.8/2.4	15	14/14	14/14	14/14	14/14	14/14
SS1XN-1½	1-1/2	208-230/460/3	4.8/2.4	15	14/14	14/14	14/14	14/14	14/14
SS1XS-1½	1-1/2	208-230/460/3	6.0/3.0	15	14/14	14/14	14/14	14/14	12/14
SS1½XN-2	2	208-230/460/3	6.0/3.0	15	14/14	14/14	14/14	14/14	12/14
SS1XS-2	2	208-230/460/3	7.0/3.5	15	14/14	14/14	14/14	12/14	12/14
SS1½XN-2½	2-1/2	208-230/460/3	7.0/3.5	15	14/14	14/14	14/14	12/14	12/14
SS1XS-2½	2-1/2	208-230/460/3	7.0/3.5	15	14/14	14/14	14/14	12/14	12/14

\*A Fusetron is recommended instead of a fuse in any motor circuit.

# ELECTRICAL

Connection diagram for dual voltage, single-phase motors. Your dual-voltage motor's terminal board (under the motor end cover) will match one of the diagrams below. Follow that diagram if necessary to convert motor to 115 Volt power. Connect power supply wires to L1 and L2.

For TEFC motors, see Figure 6, Page 7.

For 3-phase motors, TEFC motors, and motors that do not match these pictures, follow the connection diagram on the motor nameplate, or in the connection box.

## THE MOTOR IS SET FOR 230 VOLTS WHEN SHIPPED.

To change the motor to use 115 volts:

1. Turn off power
2. Remove the back motor cover.
3. Use a screwdriver or 1/2" wrench and turn the voltage selector dial counterclockwise until 115 shows in the dial opening.
4. Reinstall the motor cover.

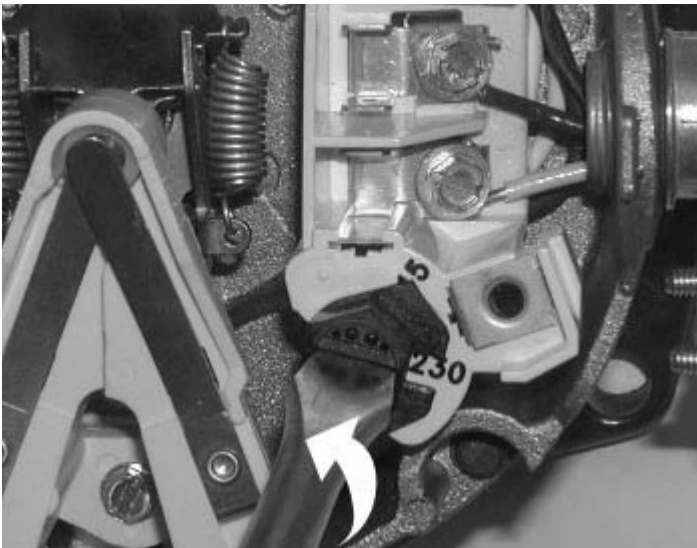

Figure 3: Changing the Voltage Setting



Figure 4: Motor Set for 115 Volt Operation

**⚠ WARNING** **Hazardous voltage.** Can shock, burn, or cause death. Disconnect power to motor before working on pump or motor. Ground motor before connecting to power supply.

## WIRING

- ⚠ **Ground motor before connecting to electrical power supply. Failure to ground motor can cause severe or fatal electrical shock hazard.**
- ⚠ **Do not ground to a gas supply line.**
- ⚠ **To avoid dangerous or fatal electrical shock, turn OFF power to motor before working on electrical connections.**
- ⚠ **Supply voltage must be within  $\pm 10\%$  of nameplate voltage. Incorrect voltage can cause fire or damage motor and voids warranty. If in doubt consult a licensed electrician.**
- ⚠ **Use wire size specified in Wiring Chart (Page 3). If possible, connect pump to a separate branch circuit with no other appliances on it.**
- ⚠ **Wire motor according to diagram on motor nameplate. If nameplate diagram differs from diagrams above, follow nameplate diagram.**

## ODP Motors, Single Phase

1. Install, ground, wire and maintain your pump in compliance with the National Electrical Code (NEC) in the U.S., or the Canadian Electrical Code (CEC), as applicable, and with all local codes and ordinances that apply. Consult your local building inspector for code information.
2. Provide a correctly fused disconnect switch for protection while working on motor. For switch requirements, consult your local building inspector for information about codes.
3. Disconnect power before servicing motor or pump. If the disconnect switch is out of sight of pump, lock it open and tag it to prevent unexpected power application.
4. Ground the pump permanently using a wire of the same size as that specified in wiring chart (Page 3). Make ground connection to green grounding terminal under motor canopy marked GRD. or  $\oplus$ .
5. Connect ground wire to a grounded lead in the service panel or to a metal underground water pipe or well casing at least 10 feet long. Do not connect to plastic pipe or insulated fittings.
6. Protect current carrying and grounding conductors from cuts, grease, heat, oil, and chemicals.
7. Connect current carrying conductors to terminals L1 and L2 under motor canopy. When replacing motor, check wiring diagram on motor nameplate against Figure 3. If the motor wiring diagram does not match either diagram in Figure 3, follow the diagram on the motor.

**IMPORTANT:** 115/230 Volt single phase models are shipped from factory with motor wired for 230 volts. If power supply is 115 volts, remove motor canopy and reconnect motor for 230 volts. Do not try to run motor as received on 115 volt current.

8. Motor has automatic internal thermal overload protection. If motor has stopped for unknown reasons, thermal overload may restart it unexpectedly, which could cause injury or property damage. Disconnect power before servicing motor.
9. If this procedure or the wiring diagrams are confusing, consult a licensed electrician.

# SERVICE

## PUMP SERVICE

This centrifugal pump requires little or no service other than reasonable care and periodic cleaning. Occasionally, however, a shaft seal may become damaged and must be replaced. The procedure as outlined below will enable you to replace the seal.

**NOTICE: Pumps use mechanical seals with a rubber seat ring or a sealing O-Ring. THESE SEALS ARE COMPLETELY INTERCHANGEABLE.**

**NOTICE:** The highly polished and lapped faces of this seal are easily damaged. Read instructions and handle the seal with care.

Some models are equipped with an impeller screw, which has a left hand thread. Before unscrewing the impeller, remove the impeller screw.

### REMOVAL OF OLD SEAL

1. After unscrewing impeller, carefully remove rotating part of seal by prying up on sealing washer, using two screwdrivers (see Figure 5A). Use care not to scratch motor shaft.
2. Remove seal plate from motor and place on flat surface, face down. Use a screwdriver to push ceramic seat out from seal cavity (see Figure 5B).

### INSTALLATION OF FLOATING SEAT (Figure 5C)

1. Clean polished surface of floating seat with clean cloth.

2. Turn seal plate over so seal cavity is up, clean cavity thoroughly.
3. Lubricate outside rubber surface of ceramic seat with soapy water and press firmly into seal cavity with finger pressure. If seat will not locate properly in this manner, place cardboard washer over polished face of seat and press into seal cavity using a 3/4" socket or 3/4" piece of standard pipe.
4. **DISPOSE OF CARDBOARD WASHER.** Be sure polished surface of seat is free of dirt and has not been damaged by insertion. Remove excess soapy water.

### INSTALLATION OF ROTATING PART OF SEAL UNIT (Figure 5D)

1. Reinstall seal plate using extreme caution not to hit ceramic portion of seal on motor shaft.
2. Inspect shaft to make sure that it is clean.
3. Clean face of sealing washer with clean cloth.
4. Lubricate inside diameter and outer face of rubber drive ring with soapy water and slide assembly on motor shaft (sealing face first) until rubber drive ring hits shaft shoulder.
5. Screw impeller onto shaft until impeller hub hits shaft shoulder. This will automatically locate seal in place and move the sealing washer face up against seat facing. Reinstall impeller screw (if used).

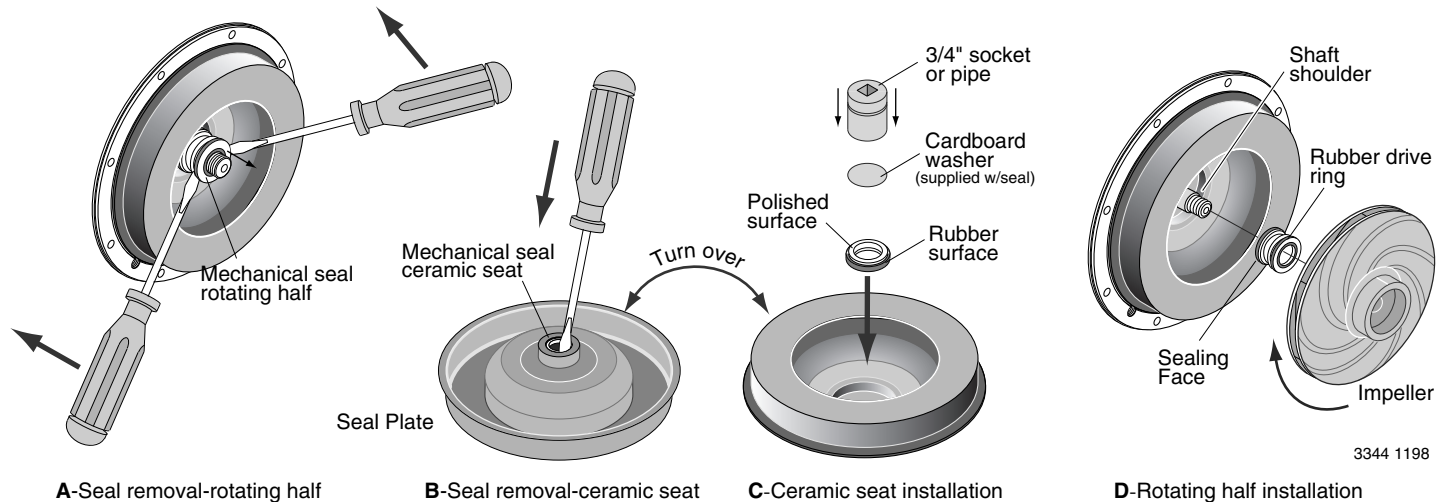
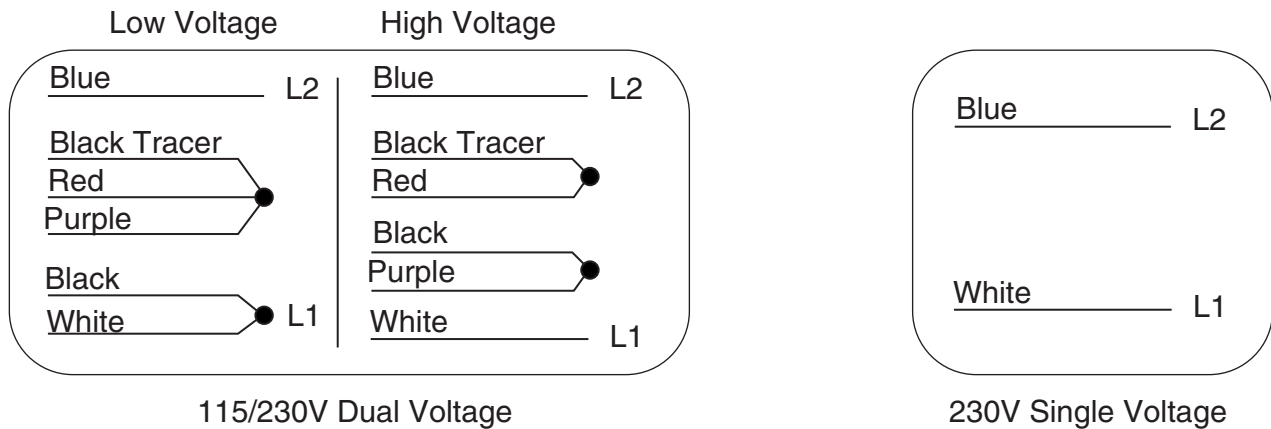

Figure 5: Seal replacement

## TROUBLE - CAUSES AND REMEDY

TROUBLE AND CAUSE	REMEDY
<b>FAILURE TO PUMP</b> 1. Pump not properly primed.	1. Make sure pump casing and suction line are full of water. See priming instructions.
<b>REDUCED CAPACITY AND/OR HEAD</b> 1. Air pockets or leaks in suction line. 2. Clogged impeller.	1. Check suction piping. 2. Remove and clean.
<b>PUMP LOSES PRIME</b> 1. Air leaks in suction line. 2. Excessive suction lift and operating too near shut-off point. 3. Water level drops while pumping, uncovering suction piping.	1. Check suction piping 2. Move pump nearer to water level. 3. Check water supply. Add length of pipe to suction to keep submerged end under water.
<b>MECHANICAL TROUBLES AND NOISE</b> 1. Bent shaft and/or damaged bearings. 2. Suction and/or discharge piping not properly supported and anchored.	1. Take motor to authorized motor repair shop. 2. See that all piping is supported to relieve strain on pump assembly.



**Figure 6: Wiring connection diagram for 115/230V Dual Voltage and 230V Single Voltage TEFC motors. If motor nameplate diagram does not match this, follow the nameplate diagram.**

# SSCX Series

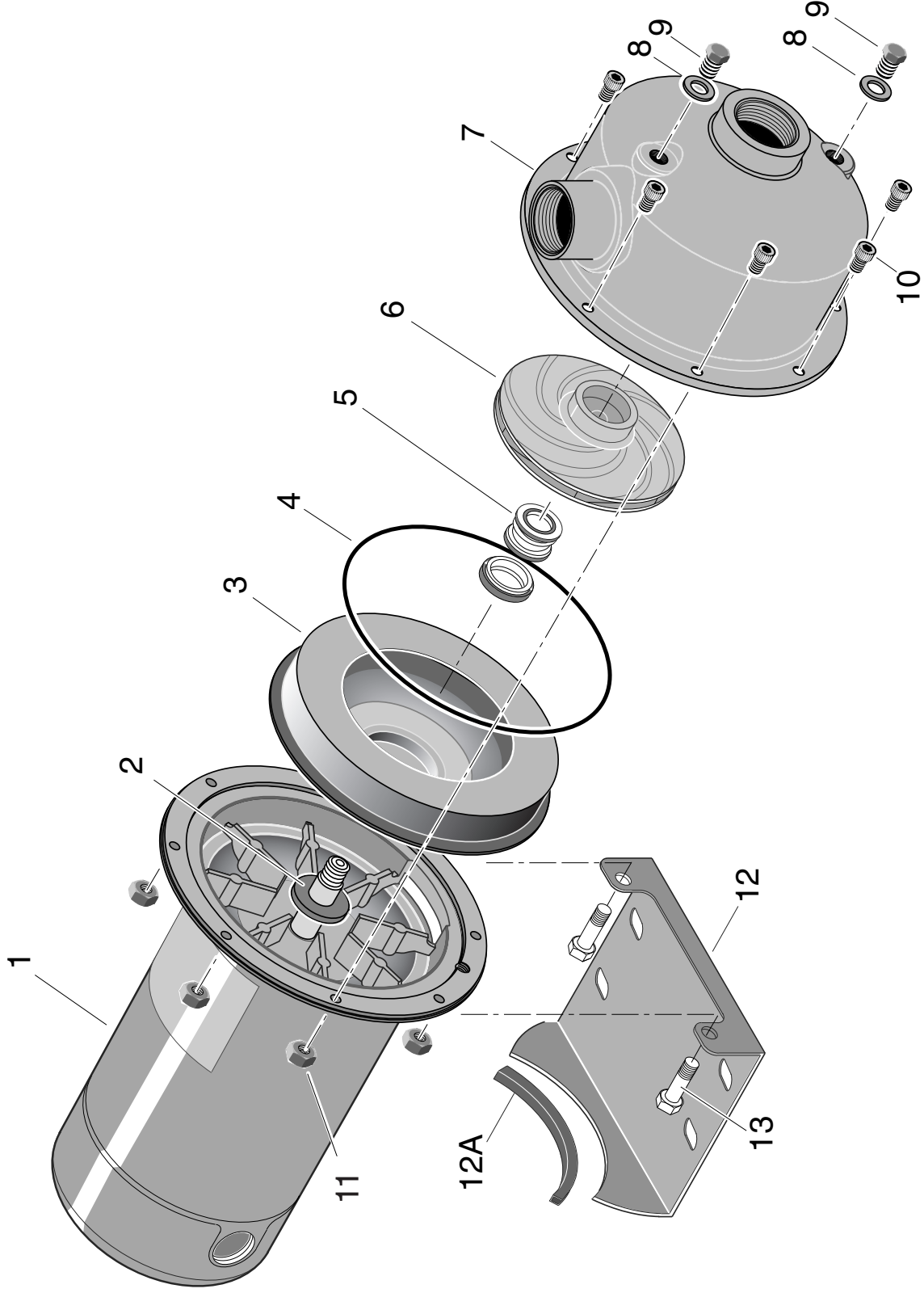

3342 1198

# REPAIR PARTS LIST

Key No.	Part Description	No. Used	MOTOR AND HORSEPOWER					
			SS1XN-1/2	SS1XN-3/4	SS1XN-1	SS1XN-1 1/2	SS1 1/2XN-2	SS1 1/2XN-2 1/2
1*	Motor, 115/230V/60 Hz., 1 Phase, ODP	1	B80440	B80441	B80442	B80443	B80444	B80445
1*	Motor, 115/230V/60 Hz., 1 Phase, TEFC	1	B80452	B80453	B80454	B80455	B80456	B80457
1*	Motor, 208-230/460V/60 Hz., 3 Phase, ODP	1	B80446	B80447	B80448	B80449	B80450	B80451
1*	Motor, 230/460V/60 Hz., 3 Phase, TEFC	1	B80458	B80459	B80460	B80461	B80462	B80463
2	Water Slinger	1	17351-0009	17351-0009	17351-0009	17351-0009	17351-0009	17351-0009
3	Seal Plate	1	C3-200SS	C3-200SS	C3-200SS	C3-200SS	C3-200SS	C3-200SS
4	O-Ring**	1	111P0490	111P0490	111P0490	111P0490	111P0490	111P0490
5	Shaft Seal***	1	U109-6A	U109-6A	U109-6A	U109-6A	U109-6A	U109-6A
6	Impeller - 1 Phase	1	C105-92PNS	C105-92PMS	C105-92PLS	C105-92PBSS	C105-214PCASS	C105-214FPASS
6	Impeller - 3 Phase	1	C105-92PNSA	C105-92PMSA	C105-92PLSA	C105-92PBSSA	C105-214PCASS	C105-214FPASS
•	Impeller Screw - 1 Phase	1	-	-	-	-	C30-14SS	C30-14SS
•	Impeller Screw - 3 Phase	1	C30-14SS	C30-14SS	C30-14SS	C30-14SS	C30-14SS	C30-14SS
7	Casing/Diffuser Assembly	1	723S2990	723S2990	723S2990	723S2990	723S3370	723S3370
8	Washer	2	111P0990	111P0990	111P0990	111P0990	111P0990	111P0990
9	Stainless Steel Plug	2	121P3780	121P3780	121P3780	121P3780	121P3780	121P3780
10	Screw	8	121P0310	121P0310	121P0310	121P0310	121P0310	121P0310
11	Nut, M6x1	8	U36-207SS	U36-207SS	U36-207SS	U36-207SS	U36-207SS	U36-207SS
12	Base	1	J104-9F	J104-9F	J104-9F	J104-9F	J104-9F	J104-9F
12	Base (1 Phase, TEFC only)	1	J104-9A	J104-9A	J104-9A	J104-9A	J104-9A	J104-9A
12A	Motor Pad	1	C35-5	C35-5	C35-5	C35-5	C35-5	C35-5
13	Capscrews, 3/8-16x3/4"	2	U30-72SS	U30-72SS	U30-72SS	U30-72SS	U30-72SS	U30-72SS

\* For repair or service to motors, always give the motor Model Number and any other data found on the Motor Model Plate.

\*\* Models B80427, B80428, B80429 and B80430 use Part Number U9-434.

\*\*\* Models B80427 and B80428 use Shaft Seal Number U109-432SS. Models B80429 and B80430 use Shaft Seal Number U9-437.

† These models use Motor Number B80445.

†† These models use Motor Number B80451.

• Not illustrated.

# SSCXS Series

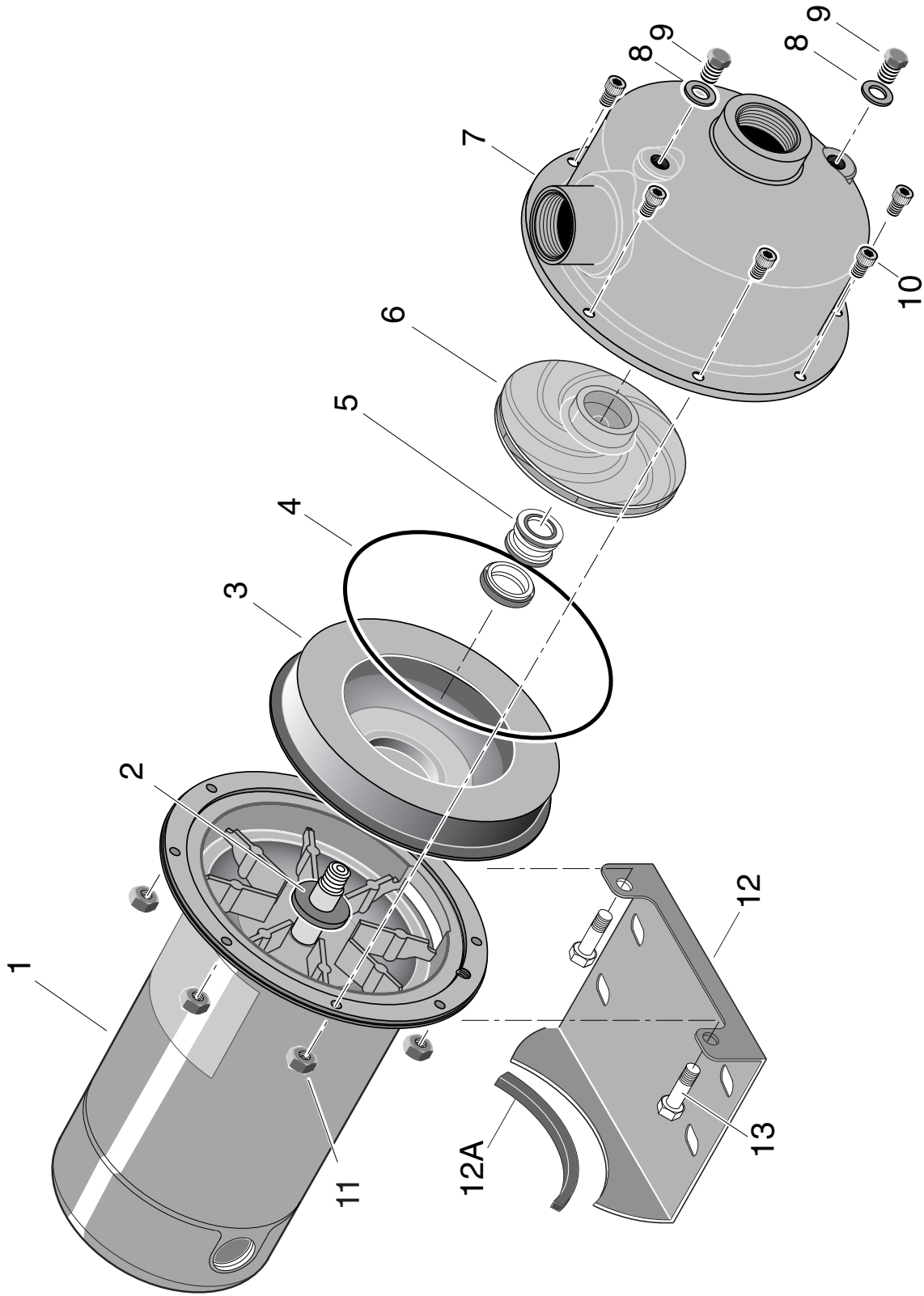

3342 1198

# REPAIR PARTS LIST

		MOTOR AND HORSEPOWER					
		SS1XS-¾	SS1XS-1	SS1XS-1½	SS1XS-2	SS1XS-2½	
		B82414 B82413 B82412 B82411 3/4 HP	B82418 B82417 B82416 B82415 1 HP	B82422 B82421 B82420 B82419 1-1/2 HP	B82426 B82425 B82424 B82423 2 HP	B82430 B82429 B82428 B82427 2-1/2 HP	
Key No.	Part Description	No. Used					
1	Motor, 115/230V/60 Hz., 1 Phase, ODP	1	B80442	B80443	B80444	B80445	B80445
1	Motor, 115/230V/60 Hz., 1 Phase, TEFC	1	B80454	B80455	B80456	B80447	B80447
1	Motor, 208-230/460V/60 Hz., 3 Phase, ODP	1	B80448	B80449	B80450	B80451	B80451
1	Motor, 230/460V/60 Hz., 3 Phase, TEFC	1	B80460	B80461	B80462	B80463	B80463
2	Water Slinger	1	17351-0009	17351-0009	17351-0009	17351-0009	17351-0009
3	Seal Plate	1	C3-200SS	C3-200SS	C3-200SS	C3-200SS	C3-200SS
4	O-Ring	1	U9-434	U9-434	U9-434	U9-434	U9-434
5	Shaft Seal*	1	U109-196A	U109-196A	U109-196A	U109-196A	U109-196A
6	Impeller	1	731S6230	731S6220	731S6210	731S6200	731S6190
•	Impeller Screw - 1 Phase	1	-	-	-	C30-14SS	C30-14SS
•	Impeller Screw - 3 Phase	1	C30-14SS	C30-14SS	C30-14SS	C30-14SS	C30-14SS
7	Casing/Diffuser Assembly	1	723S2990	723S2990	723S2990	723S2990	723S2990
8	Washer	2	111P0990	111P0990	111P0990	111P0990	111P0990
9	Stainless Steel Plug	2	121P3780	121P3780	121P3780	121P3780	121P3780
10	Screw	8	121P0310	121P0310	121P0310	121P0310	121P0310
11	Nut, M6x1	8	U36-207SS	U36-207SS	U36-207SS	U36-207SS	U36-207SS
12	Base	1	J104-9F	J104-9F	J104-9F	J104-9F	J104-9F
12	Base (1 Phase, TEFC only)	1	J104-9A	J104-9A	J104-9A	J104-9A	J104-9A
12A	Motor Pad	1	C35-5	C35-5	C35-5	C35-5	C35-5
13	Capscrews, 3/8-16x3/4"	2	U30-72SS	U30-72SS	U30-72SS	U30-72SS	U30-72SS

\* Models B82413, B82414, B82417, B82418, B82421, B82422, B82425, B82426, B82429, B82430 use Part Number U9-437.  
 • Not illustrated.

## LIMITED WARRANTY

BERKELEY warrants to the original consumer purchaser ("Purchaser" or "You") of the products listed below, that they will be free from defects in material and workmanship for the Warranty Period shown below.

<b>Product</b>	<b>Warranty Period</b>
Water Systems Products — jet pumps, small centrifugal pumps, submersible pumps and related accessories	<i>whichever occurs first:</i> 12 months from date of original installation, or 18 months from date of manufacture
Pro-Source™ Composite Tanks	5 years from date of original installation
Pro-Source™ Steel Pressure Tanks	5 years from date of original installation
Pro-Source™ Epoxy-Lined Tanks	3 years from date of original installation
Sump/Sewage/Effluent Products	12 months from date of original installation, or 18 months from date of manufacture

Our warranty will not apply to any product that, in our sole judgement, has been subject to negligence, misapplication, improper installation, or improper maintenance. Without limiting the foregoing, operating a three phase motor with single phase power through a phase converter will void the warranty. Note also that three phase motors must be protected by three-leg, ambient compensated, extra-quick trip overload relays of the recommended size or the warranty is void.

Your only remedy, and BERKELEY's only duty, is that BERKELEY repair or replace defective products (at BERKELEY's choice). You must pay all labor and shipping charges associated with this warranty and must request warranty service through the installing dealer as soon as a problem is discovered. No request for service will be accepted if received after the Warranty Period has expired. This warranty is not transferable.

**BERKELEY SHALL NOT BE LIABLE FOR ANY CONSEQUENTIAL, INCIDENTAL, OR CONTINGENT DAMAGES WHATSOEVER.**

**THE FOREGOING WARRANTIES ARE EXCLUSIVE AND IN LIEU OF ALL OTHER EXPRESS AND IMPLIED WARRANTIES, INCLUDING BUT NOT LIMITED TO THE IMPLIED WARRANTIES OF MERCHANTABILITY AND FITNESS FOR A PARTICULAR PURPOSE. THE FOREGOING WARRANTIES SHALL NOT EXTEND BEYOND THE DURATION EXPRESSLY PROVIDED HEREIN.**

Some states do not allow the exclusion or limitation of incidental or consequential damages or limitations on the duration of an implied warranty, so the above limitations or exclusions may not apply to You. This warranty gives You specific legal rights and You may also have other rights which vary from state to state.

This warranty supersedes and replaces all previous warranty publications.

**In the U.S.: BERKELEY, 293 Wright St., Delavan, WI 53115**

**In Canada: 269 Trillium Dr., Kitchener, Ontario N2G 4W5**